

TO-252 Plastic-Encapsulate Transistors

Features

- Lead Formed for Surface Mount Applications in Plastic
- Sleeves Monolithic Construction With Built-in Base & Emitter
- Resistors Pb-Free Packages are Available
- Complementary Power Transistors

MECHANICAL DATA

- Case style:TO-252 molded plastic
- Mounting position:any

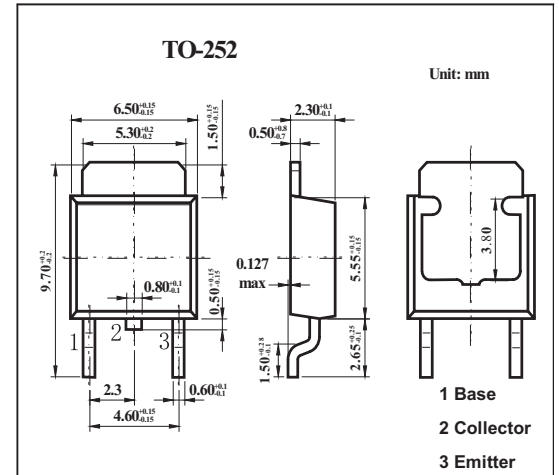

MAXIMUM RATINGS AND CHARACTERISTICS

@ 25°C Ambient Temperature (unless otherwise noted)

Parameter	Symbol	Rating	Unit
Collector-emitter voltage	V _{CEO}	100	V
Collector-base voltage	V _{CB}	100	V
Emitter-base voltage	V _{EB}	5	V
Collector current	I _C	6	A
Collector current (pulse)	I _{CP}	10	A
Base current	I _B	2	A
Total Device Dissipation FR-5 Board @T _A = 25°C Derate above 25°C	P _D	20 0.16	W W/°C
Total Device Dissipation Alumina Substrate @T _A = 25°C Derate above 25°C	P _D	1.75 0.014	W W/°C
Junction temperature	T _j	150	°C
Storage temperature	T _{stg}	-65 to +150	°C
Thermal Resistance, Junction-to-Case	R _{θJC}	6.25	°C/W
Thermal Resistance, Junction-to-Ambient	R _{θJA}	71.4	°C/W

PACKAGE INFORMATION

Device	Package	Shipping
MJD41C MJD42C	TO-252	2500/Tape&Reel

Parameter	Symbol	Testconditions	Min	Typ	Max	Unit
Collector-emitter sustaining voltage	V _{CEo(sus)}	I _C = 30 mA, I _B = 0	100			V
Collector cutoff current	I _{CEO}	V _{CE} = 60 V, I _B = 0			50	μA
Collector cutoff current	I _{CES}	V _{CE} = 100 V, V _{EB} = 0			10	μA
Emitter cutoff current	I _{EBO}	V _{BE} = 5V, I _C = 0			0.5	mA
DC current gain *	h _{FE}	I _C = 0.3 A, V _{CE} = 4 V	30			
		I _C = 3 A, V _{CE} = 4 V	15		75	
Collector-emitter saturation voltage *	V _{CE(sat)}	I _C = 6 A, I _B = 600 mA			1.5	V
Base-emitter saturation voltage *	V _{BE(on)}	I _C = 6 A, V _{CE} = 4 V			2	V
Current-gain-bandwidth product *2	f _T	I _C = 500 mA, V _{CE} = 10 V, f _{test} = 1 MHz	3			MHz
Small-signal current gain	h _{fe}	I _C = 0.5 A, V _{CE} = 10 V, f = 1 kHz	20			

*1 Pulse test: pulse width ≤ 300 μs, duty cycle ≤ 2.0%.

*2 f_T = |h_{fe}| f_{test}

hFE Classification

TYPE	MJD41C	MJD42C
Marking	J41C	J42C

